

bticino®

LIVING® LIGHT®

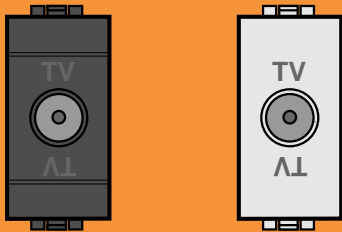

art.L4202D - N4202D

Istruzioni d'uso
Montageanleitung
Notice de montage
Instruction sheet
Instrucciones de empleo
Gebruiksaanwijzing

PART. B5629B 04/98 SC

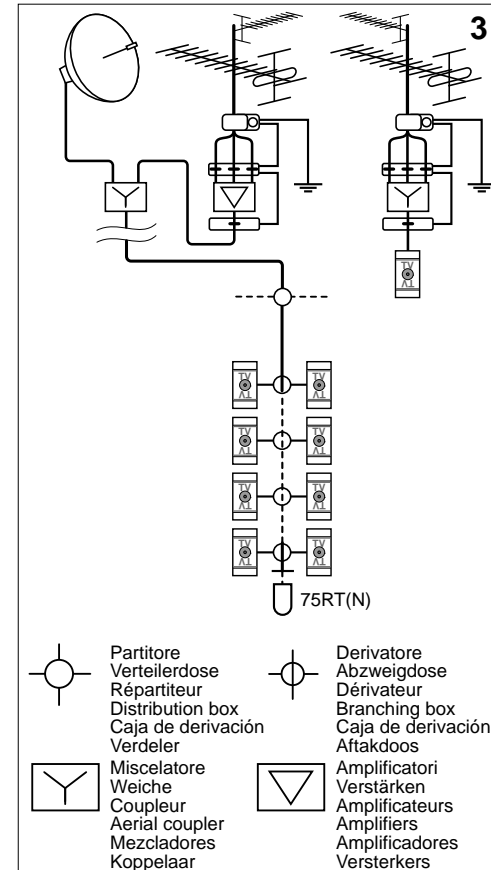
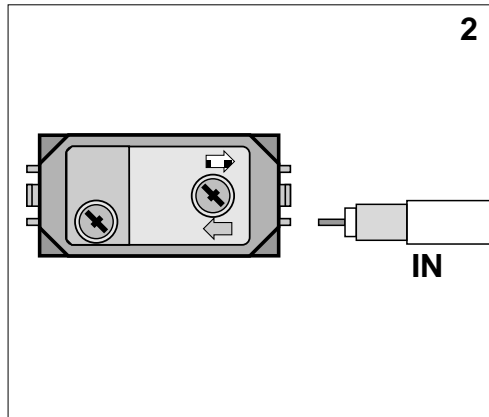
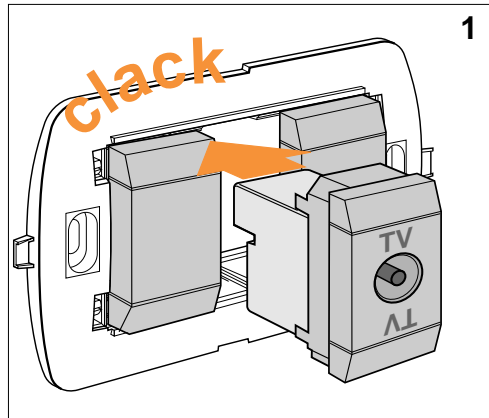

4

- Impiegare cavo coassiale con impedenza caratteristica 75Ω.
- Koaxialkabel mit Wellenwiderstand 75Ω verwenden.
- Employer du cable coaxial isolé avec impédance nominale 75Ω.
- Use coaxial cable with characteristic impedance 75Ω.
- Utilizar cable coaxial con impedancia de 75Ω.
- Gebruik coaxiaalkabel met karakteristieke impedantie 75Ω.

5

- Evitare curvature a raggio troppo piccolo e schiacciamenti del cavo coassiale.
- Biegeradien zu kleine un Pressungen des Koaxialkabels vermeiden.
- Eviter des rayons de courbure trop petits et la compression du cable coaxial.
- Avoid small bending radius and compression of the coaxial cable.
- Evitar curvaturas de radio demasiado pequeño y aplastamiento del cable coaxial.
- Vermijd sterke buiging van de coaxiaalkabel, om hem niet te pletten

6

L / N	Ad	Zo		B1	VHF	UHF	SAT IF
4202D	< 1 dB	Ω 75	mA ≤500	47-68 MHz	120-470 MHz	470-862 MHz	950-2050 MHz

Ad= Attenuazione diretta o di derivazione
Anschlussdämpfung
Atenuación de derivación
Side loss
Atenuación directa o de derivación
Attakdämpfung

Zo= Impedenza caratteristica
Wellenwiderstand
Impedance nominale
Nominal impedance
Impedancia
Nominale impedantie